

CANOVA AUTOMECH



Caratteristiche affettatrice come Canova 250-275-300:

- Struttura automatismo in acciaio inox saldato e arrotondato
- Piatto Uniko di serie
- Trascinamento carrello con sistema meccanico a biella
- Motore trascinamento ventilato a comando separato con riduttore a bagno d'olio
- Comandi separati per lama e automatismo
- Possibilità di sblocco automatismo per un funzionamento manuale
- 2 sistemi di controllo:
 - Standard on/off
 - VV: on/off con variatore di velocità
 - Produzione fette al minuto: min. 10 - max 50

The Canova Automec series offers the same outstanding features of the Canova series adding:

- *Welded and rounded stainless steel automatism structure*
- *Standard Uniko hopper*
- *Piston/rod system carriage motion*
- *Fan-cooled carriage motion motor with commercial-grade oil bath reduction*
- *Blade and carriage motion powered by separate controls*
- *An easily accessible switch arm can convert the unit from automatic to manual operation*
- *Two control systems:*
 - *Standard on/off*
 - *VV: on/off con variatore di velocità*
 - *Output slices per minute: min. 10 - max 50*



Spazioso piano per appoggio prodotto
Large tray



Piatto Uniko
Uniko hopper



Leva sollevamento, opzionale
Lifting lever, optional

Contafette opzionale
Optional slice counter

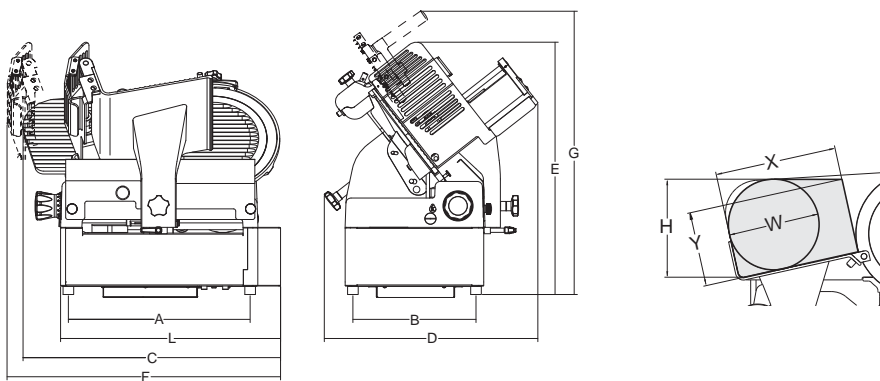

						A	B	C	D	E	F	G	L	X	Y	H	W			
	mm-inch	watt-Hp	mm	mm	mm	mm	mm	mm	mm	mm	mm	mm	mm	mm	mm	mm	mm	kg	mm	kg
Canova 300 Automec	300/12"	210+180 0,29+0,24	19	275	250x275	428	290	605	502	594	643	667	518	260	175	223	207	42.6	760x640x760	57

W

